

Manual

for Installation

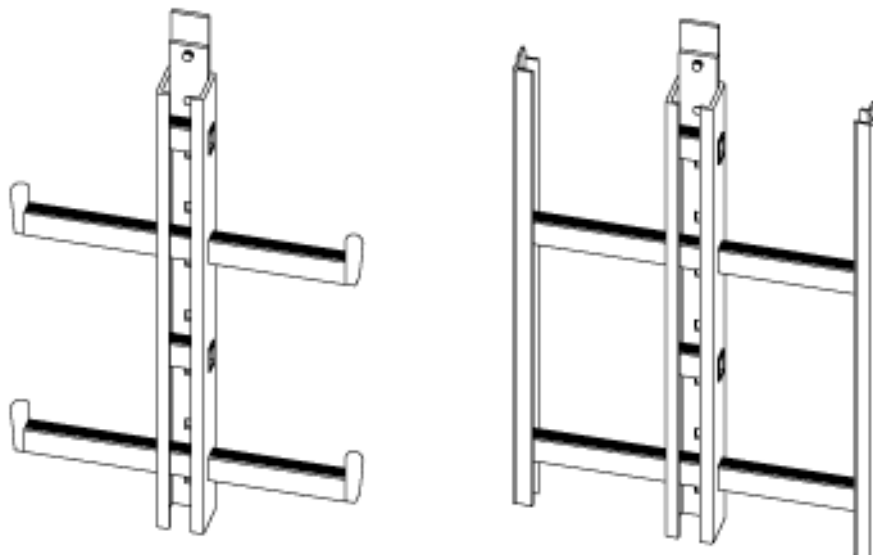
and Maintenance

of Aluminium

„Söll-GlideLoc“ fall arrest system

Y-Spar - Ladders Part No. YAL

Twin - Ladders Part No. ZAL



Date: 18.08.2008

SE 5

Technical specifications are subject to change without notice.



Table of contents

A General	3
B Installation	4
C Information regarding curves	23
D Inspection and approval	24
E Bolt connections/securing of bolts	26
F Maintenance	26
G Check list	28

These instructions are protected by copyright!

They may not be reproduced and distributed in any ways/
by any means without prior written consent of the author
according to Articles 16 and 17 of the German Copyright Act.
Sperian Fall Protection Deutschland GmbH & Co. KG will
prosecute any violations against this
under Article 106 of the German Copyright Act.

Notice!
In this issue the following has been changed: address

A General

- A 1. Anyone working with or on SÖLL fall protection systems in accordance with EN 353/part 1 must be familiarized with these instructions prior to using the system. Use which is not in accordance with these instructions constitutes a risk to human life!
- A 2. The operator of the fall protection system must ensure that these instructions are either
- retained in a dry and secure condition at the installation or
 - retained by the operator, whereby he or she must ensure that the user is aware of the storage location of these instructions and that the documents are accessible at all times.
- A 3. If requested, the plant operator must present these instructions to the manufacturer of the fall protection system (Sperian Fall Protection Deutschland GmbH & Co. KG or a dealer authorized by the same).
- A 4. The SÖLL fall protection system must be used in accordance with the instructions for the relevant SÖLL fall arrester.
- A 5. The fitment and use of SÖLL accessories to such fall protection systems must strictly adhere to the relevant instructions for the fitment and use thereof.
- A 6. In case of the use of further personal protective equipment, relevant instructions must be followed.
- A 7. National regulations on accident prevention and use of safety equipment for construction work must be adhered to.
- A 8. Söll fall protection systems may only be fitted and used with original Söll components/elements. The combination with non-original components/elements may influence the safety of SÖLL fall protection systems. In such cases, Sperian Fall Protection Deutschland GmbH & Co. KG and a dealer authorized by the same refuse to accept product liability. In addition, such systems are not properly approved and authorized since SÖLL fall protection systems are tested, approved and authorized as complete systems. Full liability will therefore rest with the operator.
- A 9. The check list (see Section G) must be fully and correctly compiled by the chief engineer of the installing company by means of an indelible pen.
- A 10. Before and during the use of the installed fall protection system, the system must be visibly inspected to ensure that it is operating properly.
- A 11. While fastening clamps, the bars may deform a little. This may cause breaks to the layer of zinc. This has no adverse effect to safety, durability or corrosion resistance.
- A 12. With a weight of 100 kg and fall factor 2 situation (worst-case scenario) the height required under the feet of the user is at least 2 m.
- A 13. The system has been tested and approved by "Stelle 0158: EXAM BBG Prüf- und Zertifizier GmbH, Zertifizierungsstelle, Dinnendahlstraße 9, 44809 Bochum.

B Installation

B 1. The installation components consist of

- several ladder sections which may be fitted as required,
- a connector consisting of an aluminum connecting part, a locking plate and 2 stainless steel locking screws M 10x25 must be fixed on each ladder section.
- a corresponding amount of mounting brackets, which must be fixed at the Y-Spar ladder (YAL) with a maximum distance of 1680mm and at the twin ladders (ZAL) with a maximum distance of 2240mm
- as may be required a certain number of rest platforms

For every climbing path at least

- 1 „Bottom End Stop“, Part No. 21051
- 1 „Top End Stop“, Part No. 51052
or one „Rigid End Stop“, Part No. 11634.

Shortening of ladders:

When shortening a ladder use templates, Part Nos. 17800 and 17996, follow instructions in instruction SE 43.

The bolts for wall anchorage must be chosen to suit the conditions of the structure, and if needed they must be design proven.

All bolt connections shall be secured using the lock washers/nyloc nuts as delivered together with the referred bolts. Refer to Section E „Bolt connections/securing of bolts“.

B 2. Equipment required for easy mounting:

- 2 open wrenches, SW 19
- 1 open wrench, SW 17
- 1 open wrench for wall bolts, according to requirements,

For mounting to existing structures:

- 2 fall arresters,
- 2 full body harnesses according EN 361,
- 1 roller extension (for a max. load of 20 kg),
purchase order no. 17563, for lifting and lowering of ladder sections,
- 1 rope for roller extension, maximum diameter 12 mm, length as required,
- 1 toolbox,
- 2 walkie-talkies, and

Min. 1 additional safety lanyard according to EN 354/355 with energy absorber for each person to protect the mounting person against falls from height during the installation.

B 3. Personnel required for installation:

two persons

B 4. Before installation, all ladder sections should be laid out in the mounting sequence (watch out for section numbers; this applies especially in case of curved climbing paths).

Caution:

If a recess (Fig. 4/Detail 1.3) is provided in one of the sections delivered, this section of the ladder must be used as **first element** of the climbing path if fitted from the bottom upward. It may **never** be used at higher levels since it would include the risk of a fall from a height, causing fatal injuries or damage to property.

B 5. Components must be handled carefully. Ladder sections must not be thrown.

B 6. Before installation, ladder sections must be cleaned from dirt - in particular on connecting surfaces. They should not come into contact with cement, mortar or similar substances. Remnants of mortar must be wiped off immediately. Especially the sliding surfaces for the fall arrester on the inside and outside of the guide-rail must be free of dirt.

B 7. Damaged parts may neither be used nor repaired but must be replaced by new ones.

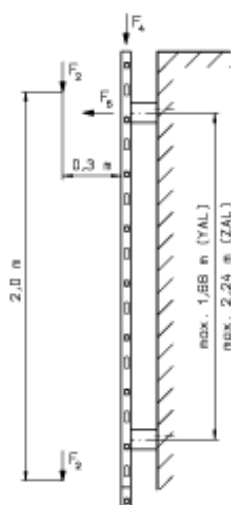
B 8. Minimum bolt dimensions for the installation of ladders:

The minimum bolt size is M 12. According to DIN 18799-3, the bolts used on chimneys must be of stainless steel A 4 DIN ISO 3506-1, at least M 20 or, when used for anchoring, 1.25 m M 12 bolts. Ordering of the mounting brackets must be based on the minimum dimensions.

B 9. We specifically stress that only those dowels may be used which are permitted by site inspection engineers.

B 10. For concrete structures we recommend the use of injection anchor or undercut dowels (such as Hilti, Fischer, UPAT or Liebig); follow technical instructions given by the manufacturer.

In case of installation on brick wall constructions we recommend you to consult the responsible design engineer for an approval in each specific case.



Use the following instructions to calculate the anchoring forces. Always select the least favourable loading result.

- **Extreme influences (fall accident):**
In case a load $F_4 = 6 \text{ kN}$ acting along the centre of the ladder is to be assumed. This load may be distributed over four mounting brackets (if available).
- **Varying influences (loads appearing during use):**
In this case it shall be assumed that loads $F_2 = 1,5 \text{ kN}$ appears at a distance of 30 cm in front of the ladder centre and in distances of 2 m from each other influence the installation. Also consider a horizontal load $F_5 = 0,3 \text{ kN}$ influencing the attachment at the most unfavourable location.

- B 11. Mounting distance
recommended: **1400 mm**
maximal: for Y-spar (YAL) 1680 mm
for twin ladder (ZAL) 2240 mm
- B 12. When the climbing path ends on a platform, the ladder/guide-rail must rise at least 1000 mm above the upper edge of the platform. If the last anchorage point is situated more than 525 mm below the end of the rail, a reinforcement profile of 50 x 50 x 4 mm has to be used that:
- extends over the last two mounting brackets
 - is connected to the rail at distances of 560 mm
 - does not have any rail connection
- B 13. In case of lying structures (e.g. antenna towers) or in case a scaffolding is at hand we recommend the ladder system be installed from the **top and downwards**.
- For upright structures (e.g. buildings) the installation shall be performed from the **ground and upwards**.
- B 14. **Caution:** By using a mounting distance of 1120 mm, the installation of the ladder may be carried out without a scaffold. When using a greater mounting distance, an installation scaffold is required. The person installing the equipment uses a full-body harness and a fall arrester. In order to be protected against a fall from a height where the fall arrester slips from the rail, or the not completely installed ladder bends backwards, the installer must always use a safety lanyard with shock absorber in accordance to EN 354/355 or a retaining rope in accordance with EN 358 (see Fig. 1).

Warning!

The proper functioning of the fall arrester can only be guaranteed in that part of the guiding rail that is located between gated end stops as well as during proper use.

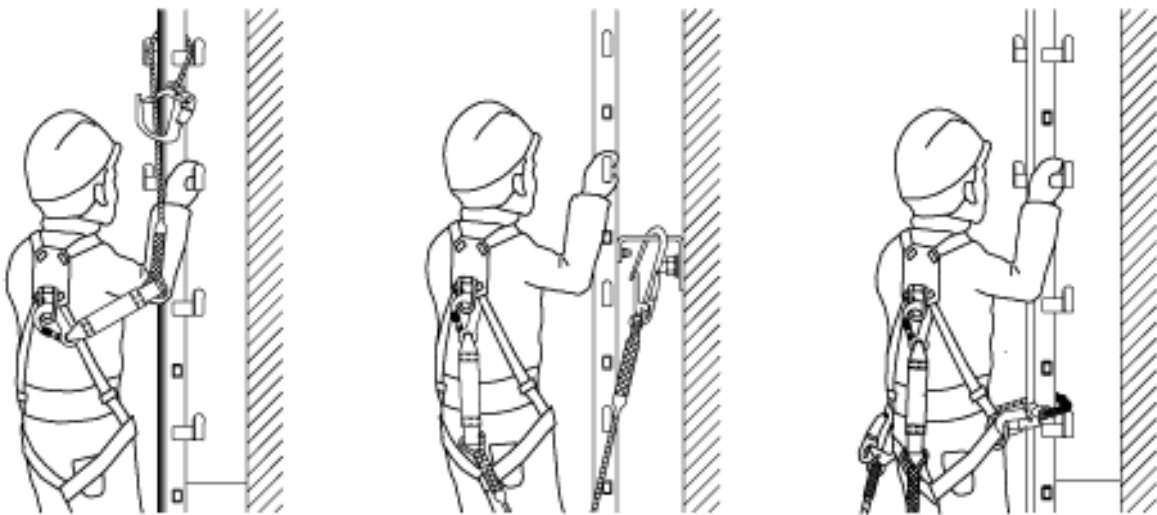
Installation or dismounting of the fall arrester on the guiding rail as well as moving beyond the gated end stop may only be done in a safe position (e.g., firm ground, safe platform).

Fig. 1

B 15. Erection staff can during the installation secure themselves by using:

- Safety lanyard (acc. to EN 354/355) connected to the center rail to the ladder under the highest situated properly secured mounting bracket
- The carabiner of a safety lanyard (EN 354/355) is connected to a mounting bracket
- Support lanyard (EN 358) routed around the centre rail of the ladder
- The use of an external anchorage point

Fig. 1



EN 354/355

EN 358

Warning:

Never use the side stringer of a twin ladder for anchorage purposes!

Fig. 2a, b, c

- B 16. Before fixing the ladder sections to the structure, the mounting brackets (2.0) are loosely pre-fixed on the central spar of the ladder (1.1) at a maximum distance of 1680mm (YAL) and at a maximum distance of 2240mm (ZAL).

Important:

Every ladder section should be connected to the support structure by at least one mounting bracket!

Explanation:

Two ladder sections connected by an exit device (order nr. 10550) must be considered as one ladder section. **An exit device does not represent an interruption of the ladder!**

Notice:

Many years of experience lead to the following recommendations:

- ➔ use ladder sections with a length of at least 1680 mm to ensure that every ladder section automatically will have at least one mounting bracket
- ➔ ladder sections with a length shorter than 1680 mm shall preferable be used in the beginning of the system
- ➔ the last ladder section should be installed using two mounting brackets
- ➔ Should an existing system have to be extended with a ladder section shorter than 1680 mm, do not install that section at the end of the system but rather between two already installed taller sections.

Warning:

The **recommended fixing distance is of 1.400mm**; for Y-Spar ladders (YAL) the maximum distance is 1680mm and for Twin ladders (ZAL) the maximum distance is 2240; however, at least 4 mounting brackets must be used to fix each climbing path.

Exceptions:

For ladder sections with a max. length of 2240 mm the use of two mounting brackets is acceptable. For sections up to 3920 mm a minimum of three brackets shall be used. Make sure that the mounting brackets used (and their support structure) are suited to absorb a load of 6 kN. (see sect. B 10)

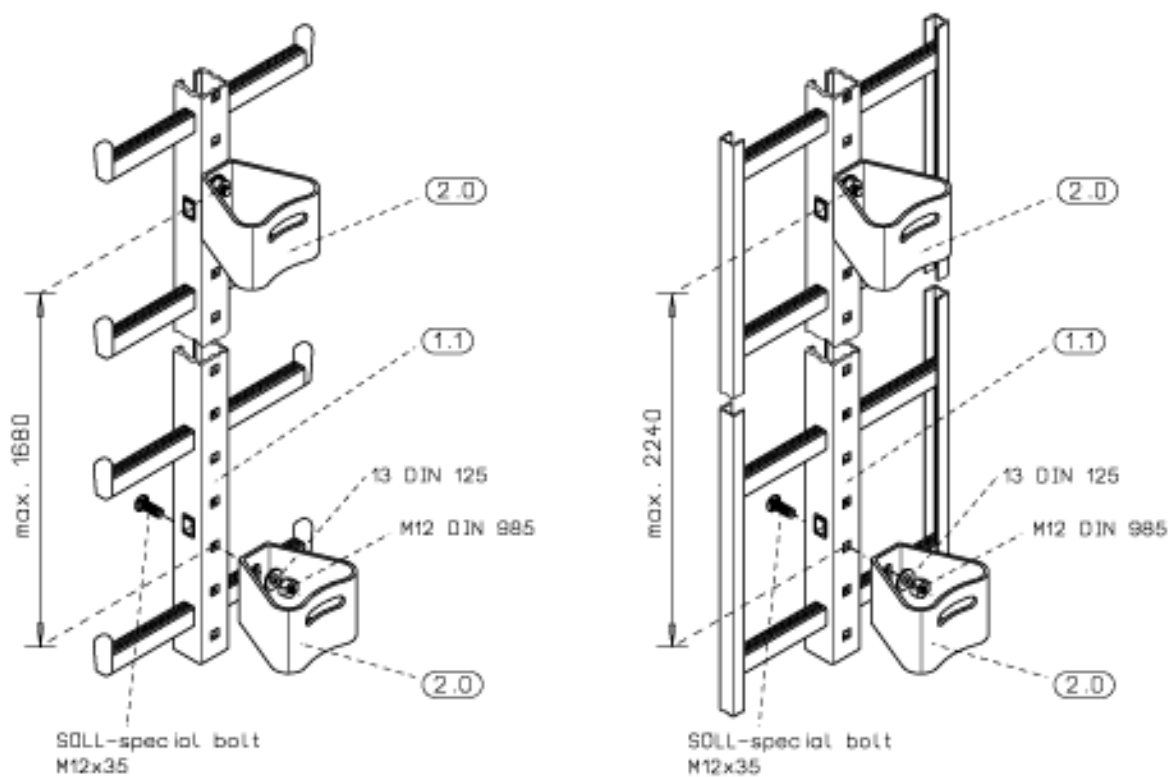
Fig. 2a

Fig. 2b Mounting distance: 1680mm

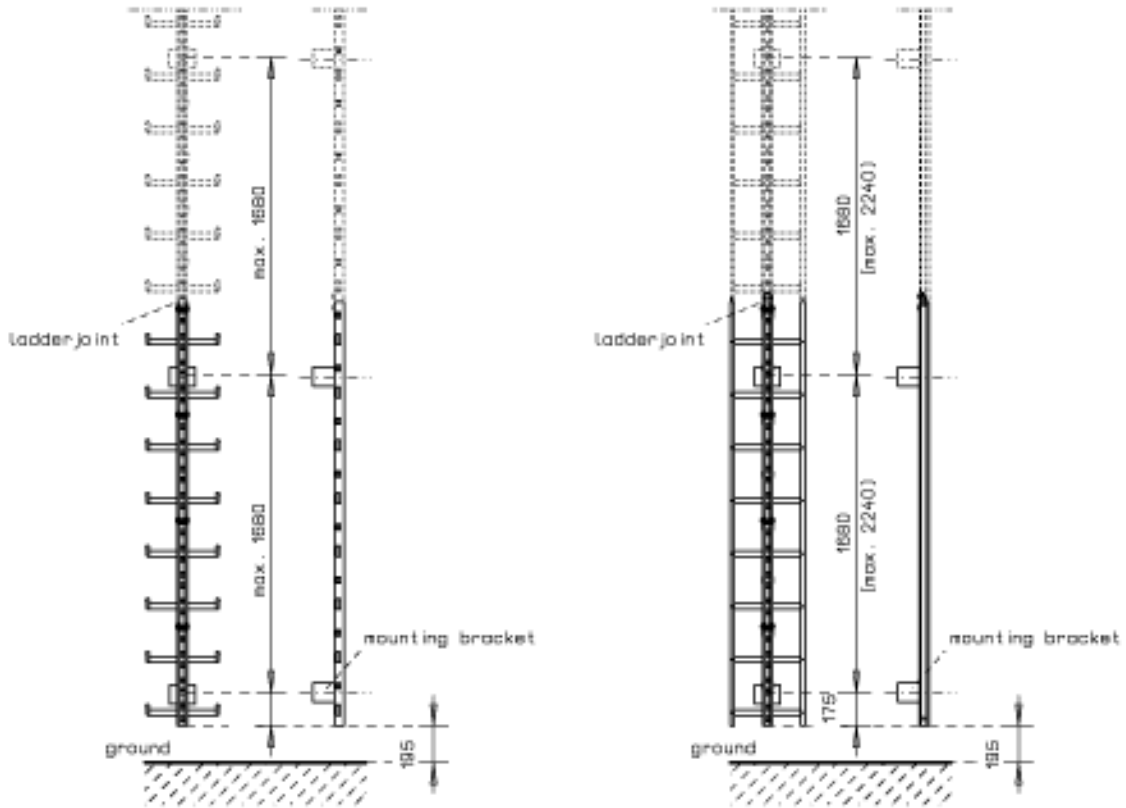
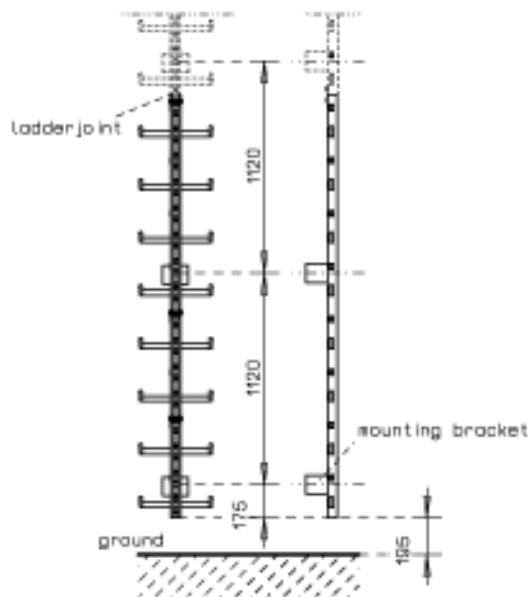


Fig 2c Mounting distance: 1120 mm



B 17. Torque ranges:

When tightening mounting screws in **steel quality 8.8** used in combination with tooth lock washers the following tightening torque range is recommended:

Screw size:	M 10	M 12	M 16	M 20
	20 Nm	25 Nm	60 Nm	120 Nm

When tightening mounting screws in **stainless steel quality 1.4571** in combination with Söll supplied auto-locking nuts (DIN 985) the following torque range is recommended:

Screw size:	M 10	M 12	M 16	M 20
	40 Nm	45 Nm	85 Nm	150 Nm

Fig. 3

- B 18. The first ladder section with red plastic ribbon (3.0) pointing upwards is put onto the mast. The mounting bracket (2.0) is attached to the structure with the appropriate wall anchorage bolt. The ladder section is brought in vertical line by means of oblong holes (2.1) in the brackets. Make sure that bolts are properly secured (see Section E).

Warning:

The red ribbon plastic (3.0) at the top of each ladder section is not an end stop! It will not prevent the fall arrester from slipping out of the rail!

Fig. 3

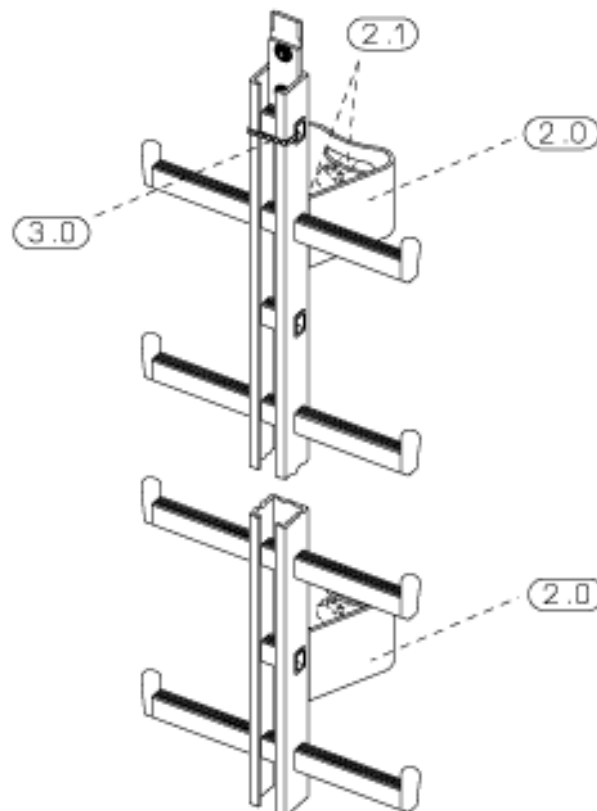


Fig. 4

- B 19. If it has not already been pre-assembled in the factory, bolt the „lower ascending lock“ (4.0) to the ladder from behind through the square hole (1.4) of the center stile (1.1) in such a way that the „lower ascending lock“ (4.0) is at least 240 mm but no more than 590 mm above the groove (1.3). The lock bolt (4.1) must then be on the right side of the center stile (1.1).

Fig. 4

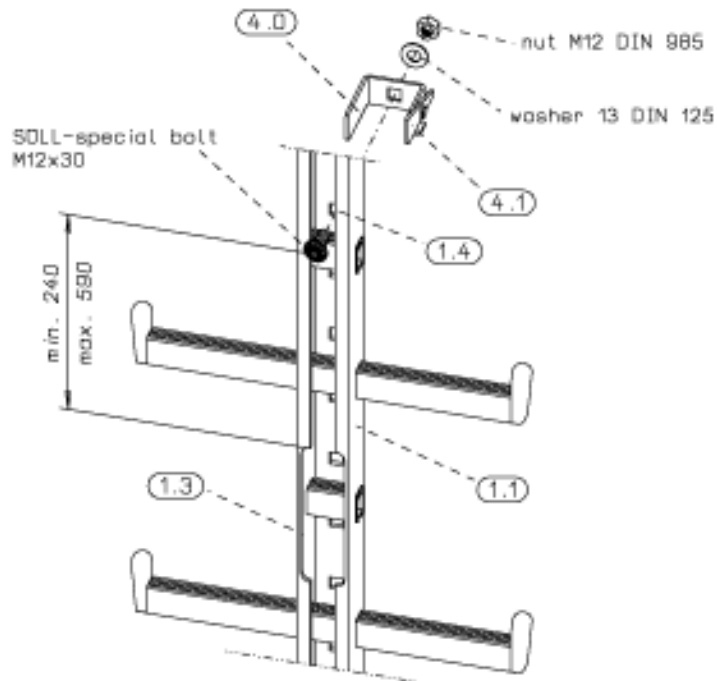


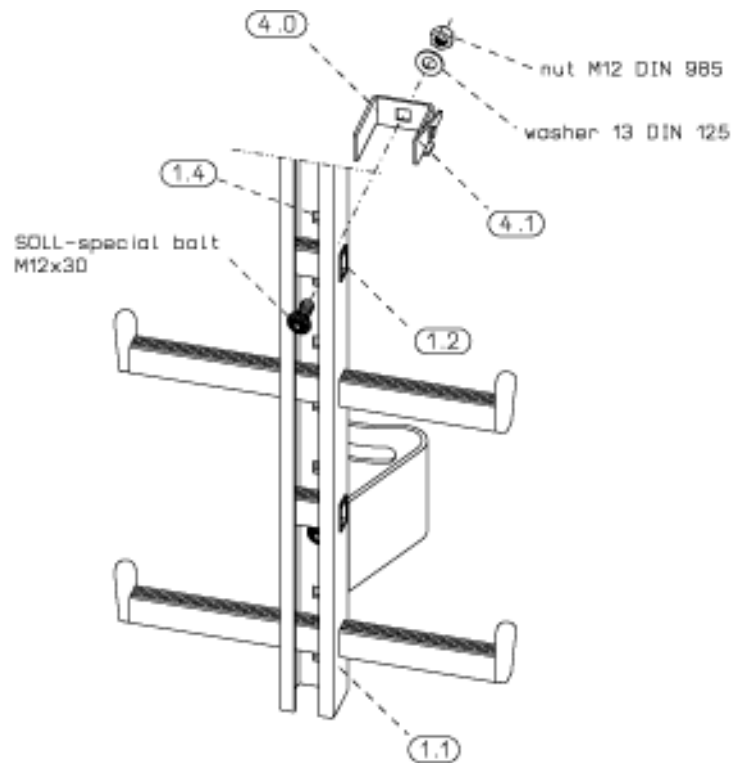
Fig. 5

B 20. When there is no recess, the „Bottom End Stop“ (4.0) is to be installed directly above the first catch (1.2) as shown.

Caution!

Make sure, that the pivotable lever (4.1) of the „Bottom End Stop“ is on the right hand side of the guide rail (1.1).

Fig. 5



Warning:

In order to prevent the incorrect insertion of the **fall arrester**, it must only be inserted **after** the „**Bottom End Stop**“ has been installed.

Warning:

The red PVC-strap (see fig. 3/det. 3.0) must only be surpassed with a fall arrester when the next ladder section:

- is properly connected to the lower ladder section
- and is attached to the support structure by means of at least one mounting bracket.

The upper ladder ladder section must lie flush with the lower ladder section (see sect. C).

During the installation work the fall arrester must never pass the last bracket that has been properly attached to the support structure (refer to item B 14/B 15).

B 21. Special case:

If a vertical ladder is not mounted directly at ground level, 2 „lower ascending locks“ must be fitted:

- the first (A) immediately at the beginning underneath the 2 arrester blocks of the ladder, in order to prevent incorrect attachment of the fall arrester (see also Point B 19., B 20.), and
- the other (B) at a height of approx. 1,645 mm, in order to prevent the operator from losing his footing when descending.

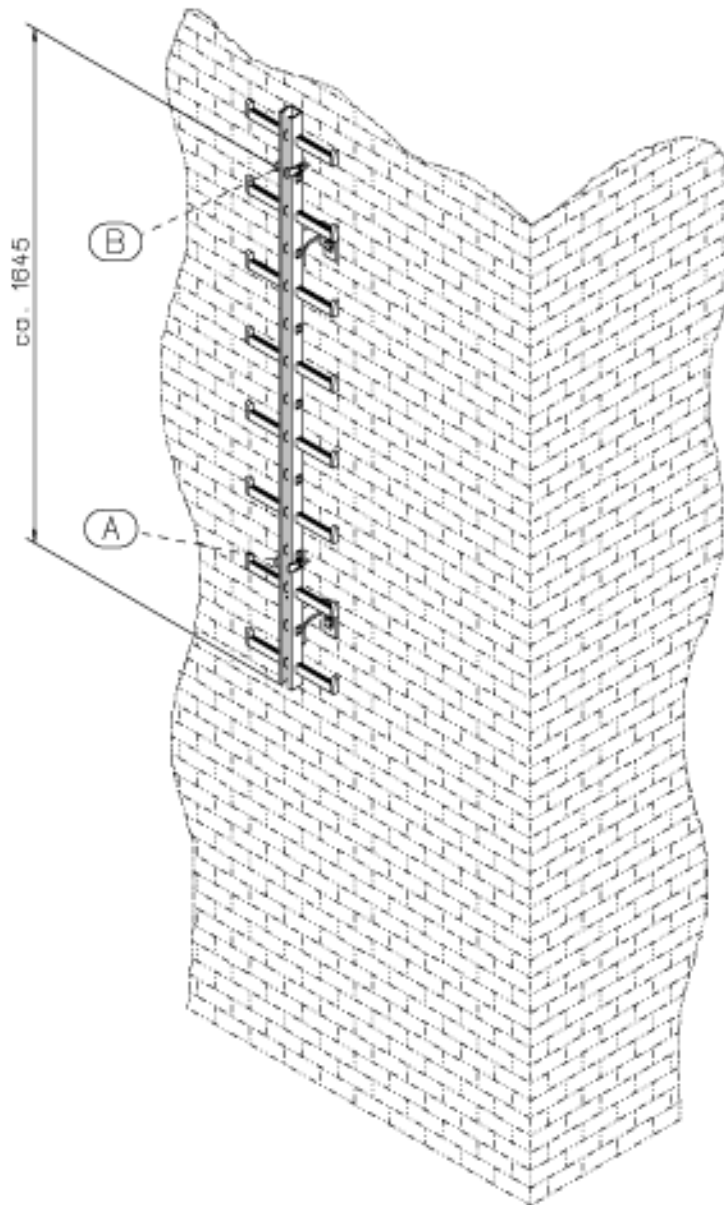
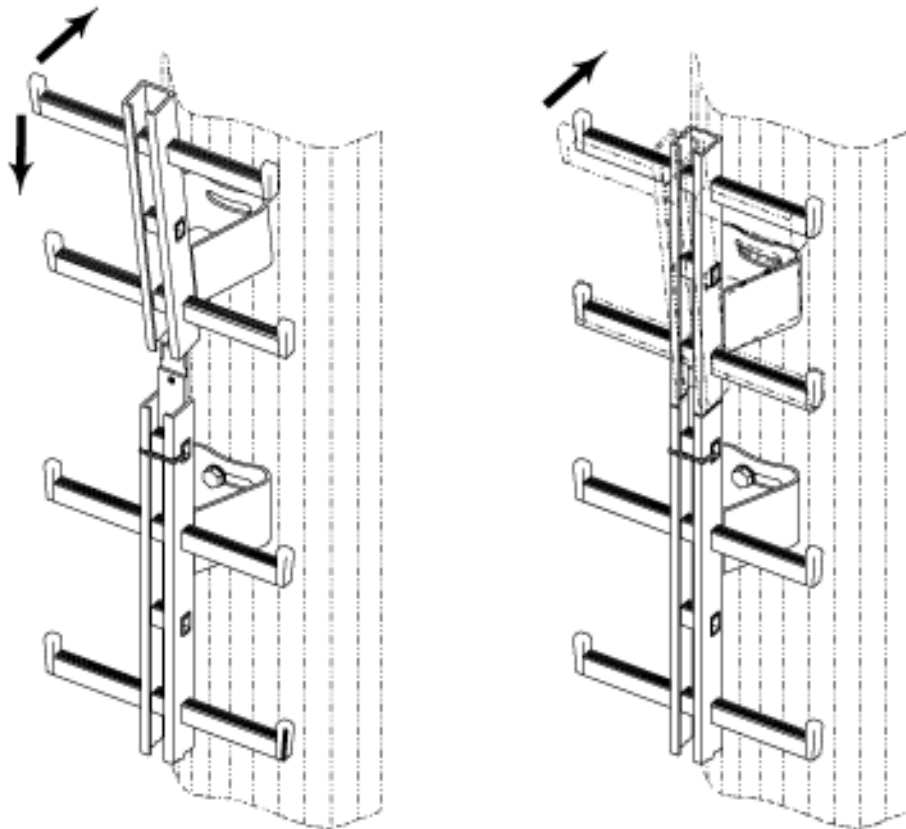


Fig. 6

B 22. The next ladder section to mount must be rested against the structure and inserted vertically into the ladder section which has already been fixed.

Fig. 6

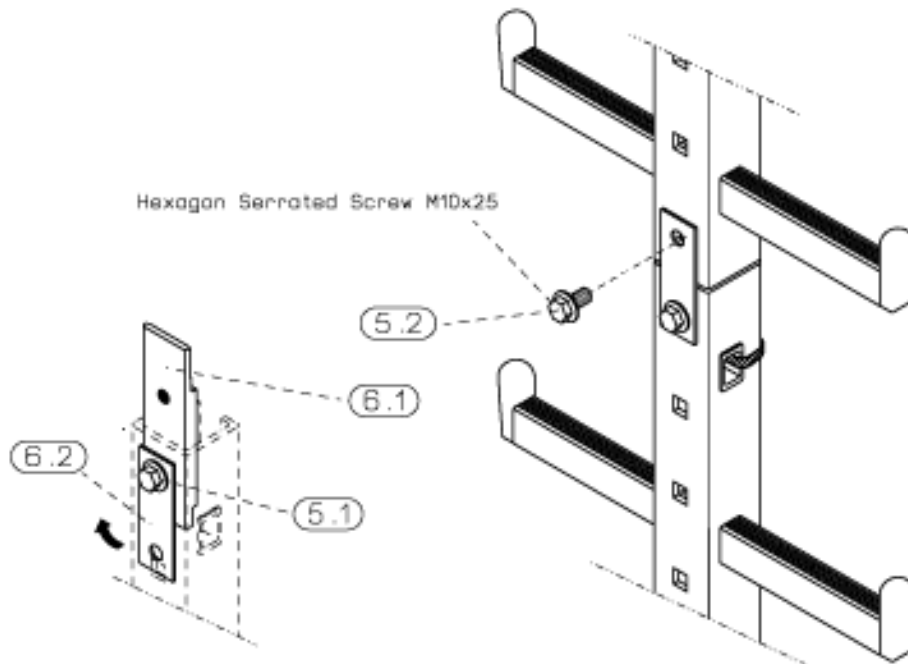
B 23. **Minimum Gap Width:**

Mounting recommendations:

- Under positive ambient temperature, gap width 2 mm
- Under negative ambient temperature, gap width 3 mm
- During re-examination, make sure that the maximum gap width of 5 mm is not exceeded (independently from the ambient temperature)

Fig. 7

- B 24. Loosen the lower screw (5.1) of the connecting part (6.1) and turn the locking plate (6.2) upwards. Screw on the upper screw (5.2) from behind through the locking plate. Adjust the gap length and screw down the screws (5.1/5.2) with a 30Nm torque.

Fig. 7

- B 25. Mount the lower bracket of the upper section to the wall.
- B 26. **Now** cut red plastic ribbon (Fig. 3/Detail 3.0) of the lower ladder section.

B 27. During the installation work ensure that:

- in the **X-direction** ladder sections are **vertically** installed
- in the **Y-direction** ladder sections are located in the range of **0° bis 15°**.

Exception:

In case of curved systems follow angle directions given in **chapter C** !

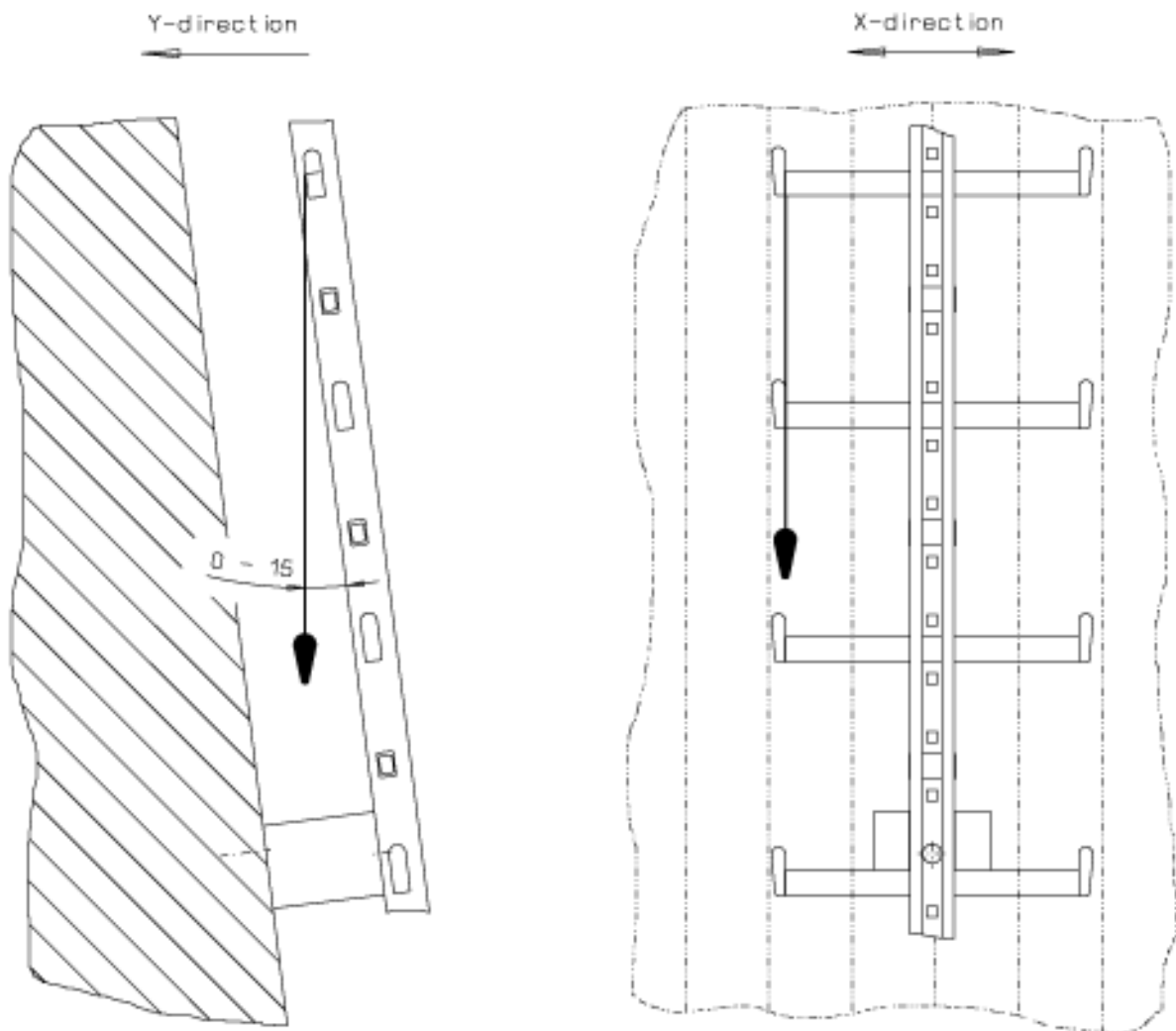


Fig. 8

B 28. Caution:

When the climbing path ends on a platform, the ladder must rise at least 1000 mm above the upper edge of the platform. For design reasons the guide rail of the ladder must be reinforced if, at the end of the ladder run, the guide-rail rises more than 525 mm above the last mounting bracket. **Projections of more than 525 mm without extra reinforcement are not permitted.**

Warning:

Unsupported ladder sections with a length of more than 525 mm are not allowed without reinforcement profiles!

When installing the aluminium reinforcement profile 50 x 50 x 4 mm the following shall be noted:

- the reinforcement profile shall be connected to the ladder from the rear at intervals of 560 mm
- the reinforcement profile must extend downwards over at least two mounting brackets
- along the total length of the reinforcement profile no ladder joints are allowed
- the reinforcement profile must be in one section only

Fig. 8

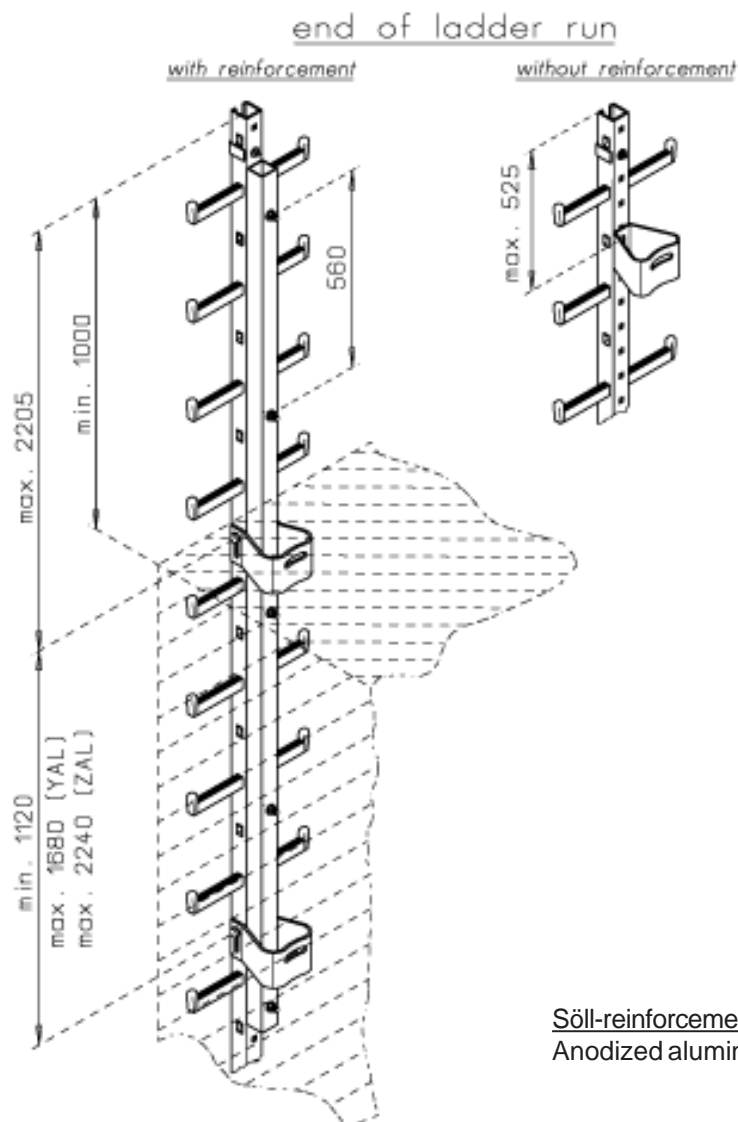


Fig. 9a and 9b

B 29. At the upper end of the climbing path the „Top End Stop“ (7.0) has to be installed, as a rule the „Rigid End Stop“ (8.0), has to be installed. The „Top end stop“ can be installed at a maximum distance of 315mm from the end of climbing path. **The „Top End Stop“ prevents the fall arrester from being inserted incorrectly and from sliding out incidentally.** To remove the fall arrester, the lever (7.1) must be pivoted downwards to the end stop. **The rigid end stop (8.0) prevents generally the fall arrester from leaving the guide rail.**

Caution:

The "Top End Stop" must be installed in such a way, that the pivotable lever (Fig. 9a/detail 7.1) is to the right hand side of the rail. The "Rigid End Stop" must be installed in such a way that both of its sides (Fig. 9b/detail 8.1) embrace the rail from the front as shown.

Fig. 9a

„Top End Stop“

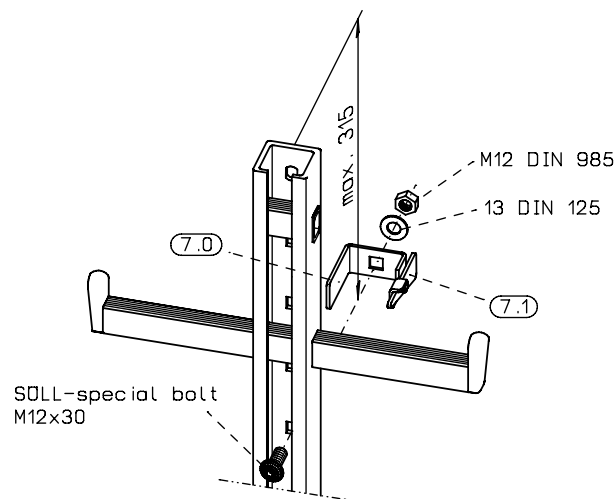


Fig. 9b

„Rigid End Stop“

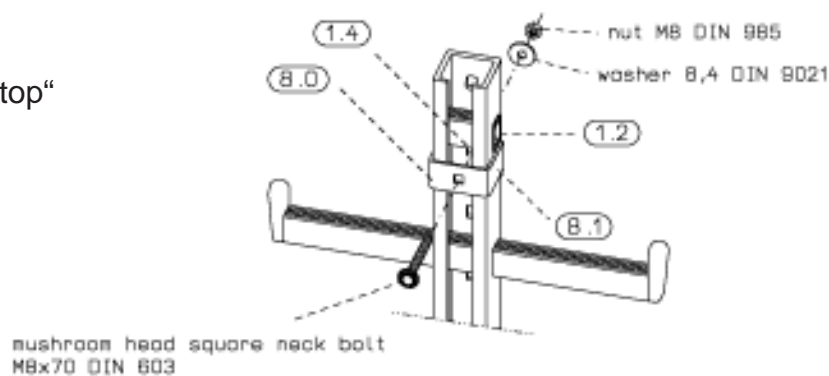


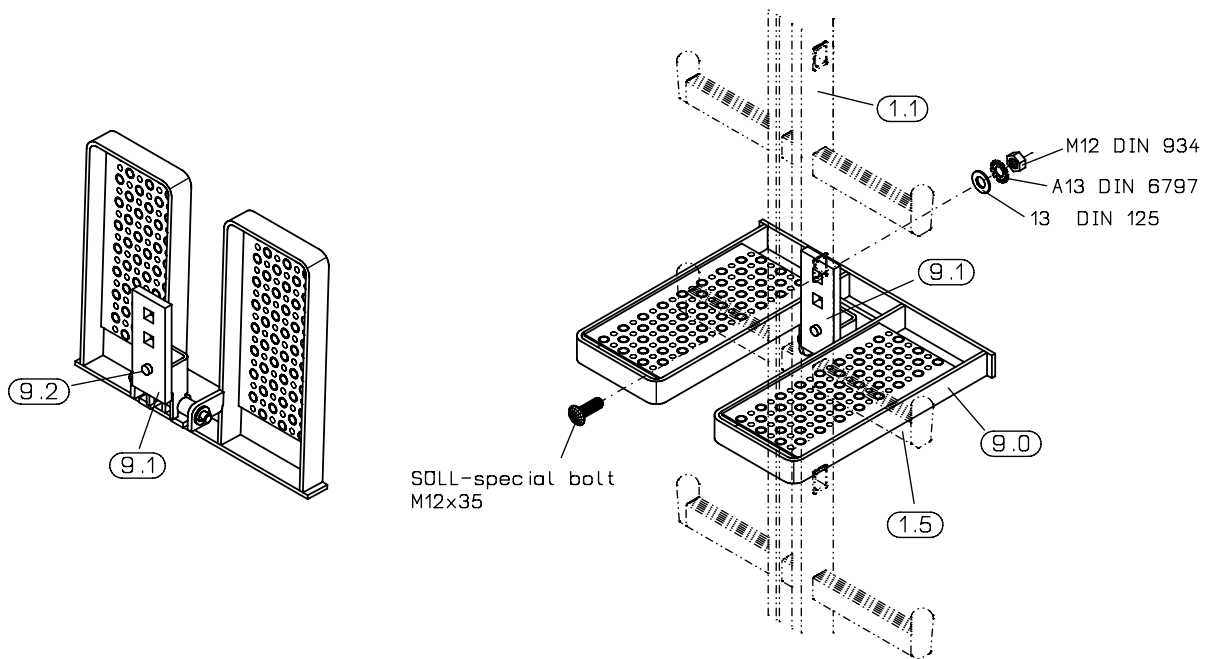
Fig. 10a and 10b

B 30. Mounting of foot rests (9.0) (10.0) **without** spar support

Version: Steel, hot-dip-galvanized, part No. 23722

If included in delivery, secure the hinge of the rest platform (9.1) by inserting the enclosed Söll special bolt M12x35 through the 2nd square hole **about** the rung (1.5) on the center stile (1.1). The fixture (9.2) must then point to the 1st square hole **about** the rung (1.5).

Fig. 10a



Installation hint:

The folded down footrest shall rest upon the rung (1.5)!

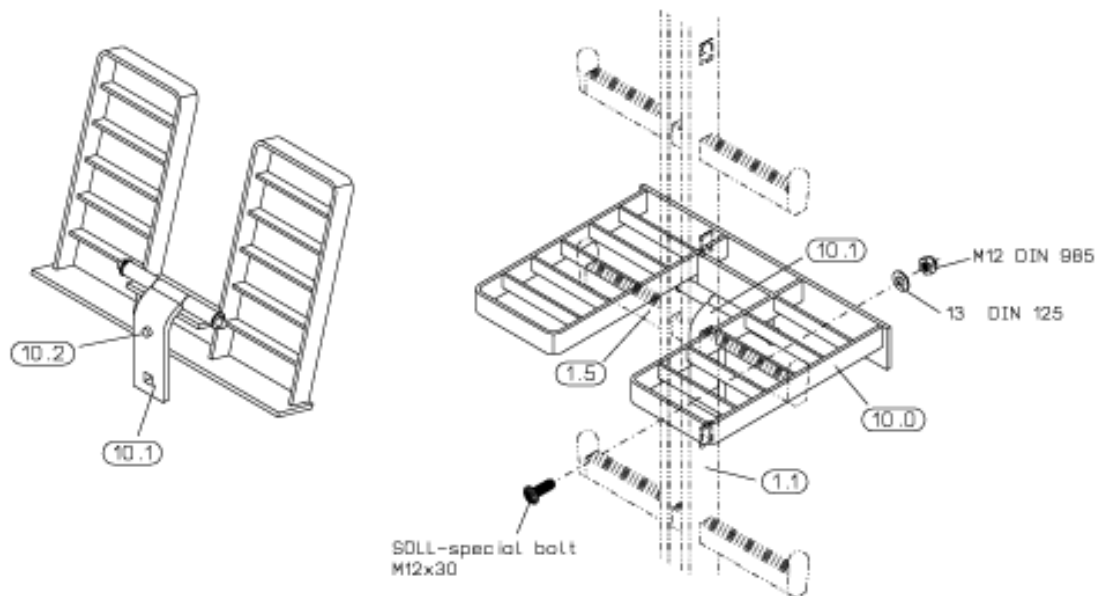
Note!

Install rest platforms as local regulations may require.

Version: Stainless steel, part No. 17351

If included in delivery, secure the hinge of the rest platform (10.1) by inserting the enclosed Söll special bolt M12x30 through the 2nd square hole **under** the rung (1.5) on the center stile (1.1). The fixture (10.2) must then point to the 1st square hole **under** the rung (1.5).

Fig. 10b



Installation hint:

The folded down footrest shall rest upon the rung (1.5) !

Note!

Install rest platforms as local regulations may require.

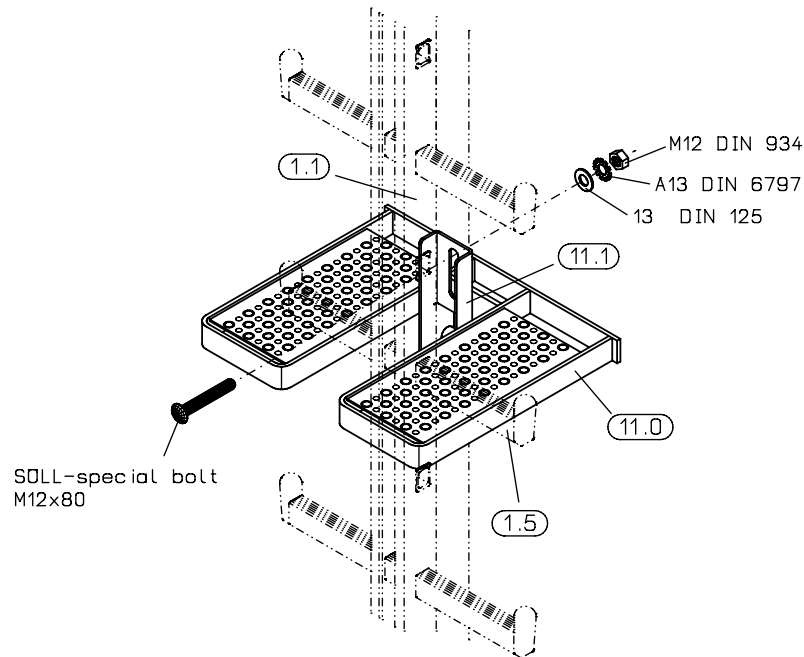
Fig 11

B 31. Installation of rest platforms (11.0) when reinforcement profile is used

Version: Steel, hot-dip-galvanized, part No. 23980

If included in delivery, the hinge (11.1) has to be fixed to the central spar (1.1) with the included special bolt M12x80 through the 2nd. square hole above the rung (1.5.). For this purpose, a drilling of 13mm Ø has to be done in the spar support at the same height of the 2nd. square hole above the rung (1.5) before assembling.

Fig. 11



Installation hint:

The horizontal folded down platform shall rest upon a rung (1.5)!

Note!

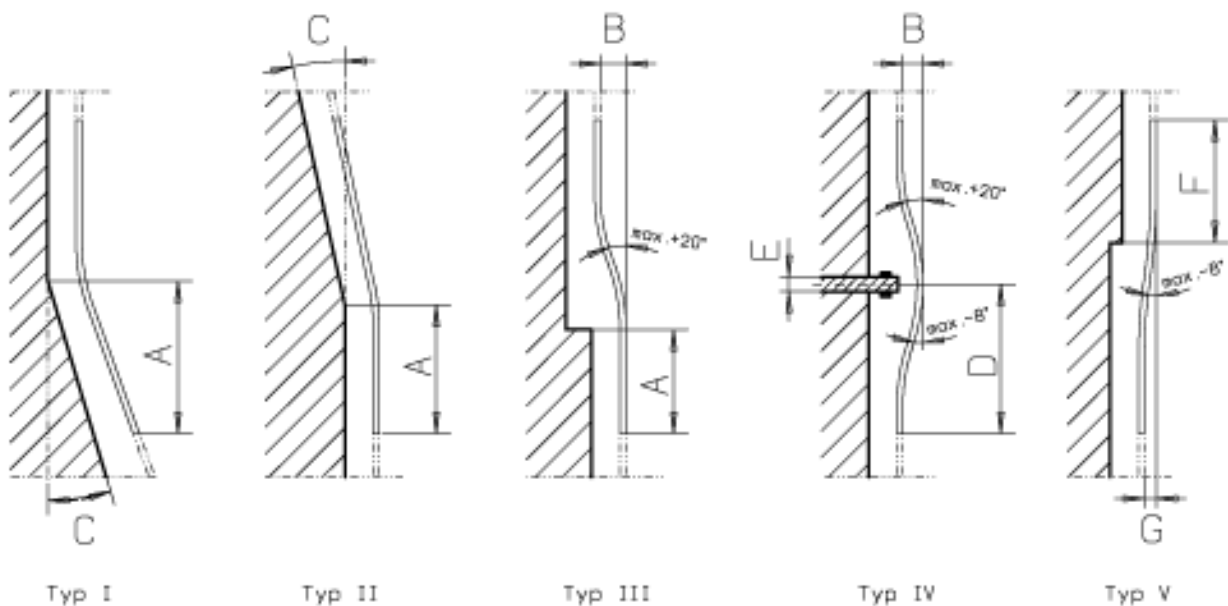
Install rest platforms as local regulations may require.

C Information regarding curves

- C 1. For aluminium ladders the below are the smallest possible bending radii:
- | | |
|------------------------|---------|
| Type Y-spar (YAL) | 3000 mm |
| Type twin ladder (ZAL) | 3000 mm |

- C 2. Curvetypes

Fig 12



- A** = Bottom edge of ladder to salient point of structure
B = Of-set
C = Angle (max. 15°)

- D** = Bottom edge to centre of obstruction
E = Width of obstruction
F = Upper edge of ladder to off-set
G = Of-set (max 260 mm)

- C 3. For fall arrest systems type "GlideLoc™" the following are the maximum permissible curve angles:

Curve type	max. curve angel
III	+ 20 °
IV	- 8 ° up to + 20 °
V	- 8 °

D Inspection and approval

Note:

Particular attention is required when ascending and descending the first 2 m of ladder, as it may not be possible to prevent the user from falling to the ground.

Both before and during use, consideration should be given to how rescue operations can be performed safely and effectively.

A fall protection device according to EN 353 Part 1 should only be used by persons who

- have been trained and/or are otherwise proficient in its use, or
- are under the direct supervision of a person who has been trained and/or is otherwise proficient in its use.

Fig. 13

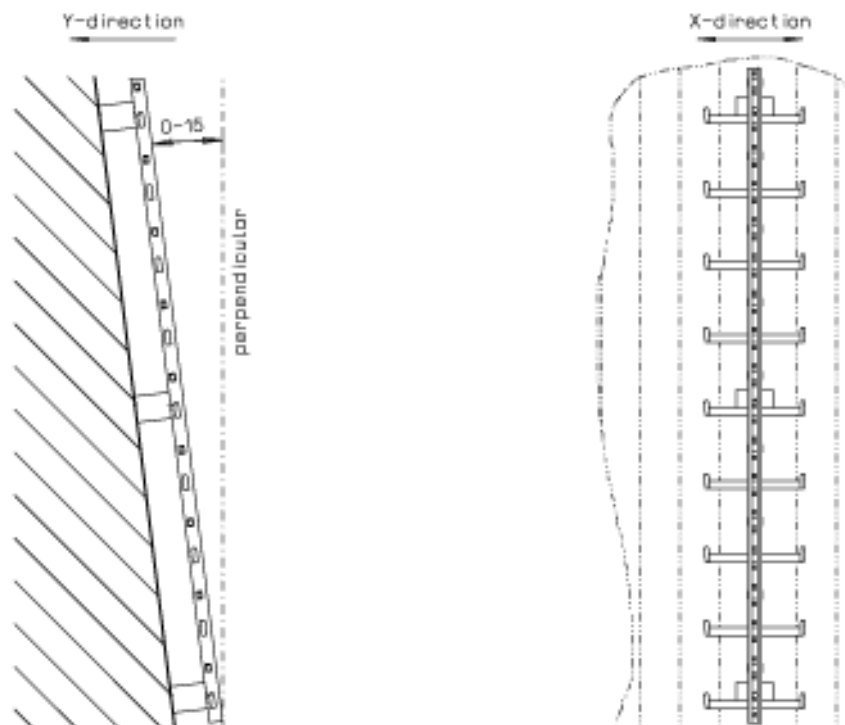
At the "OK to climb" inspection the following details have to be considered:

- Every ladder section needs to have at least one mounting bracket
- The connection between two ladder sections must be flush and smooth
- In the **X-direction** ladder section shall be **vertical**
- In the **Y-direction** the angle between the vertical line and the ladder sections may range from **0° bis 15°**. (Exception: in the area near bends)
- Curves must be made in accordance with instructions in chapter C.
- Always check the following screw connections:
 - ➔ mounting bracket to support structure
 - ➔ mounting bracket to ladder rail
 - ➔ connections between ladder sections
 - ➔ attachment of end stops to rail
- all screw connections have to be properly tightened and secured against unintended opening (refer to section E). Even bolts pre-assembled in the factory must be checked and secured where appropriate.
- the stop lever in end stops must automatically fall into lock position.

Note:

Installer shall agree with system owner about the necessary quantity of fall arresters (e.g. Compact) needed. Every system shall include at least two fall arresters.

Fig. 13



E Bolt connections/securing of bolts

At use of hot dip galvanised screws the tooth washer ensures satisfactory securing of the screw/nut connection.

At use of stainless steel screws self-locking nuts (nyloe or similar) shall be used.

Bei den Kupplungsstücken der Leiter ist die Schraubsicherung durch die Verwendung der mitgelieferten Sperrzahnschraube gewährleistet.

F Maintenance

Warning:

The fall arrest system must not be used if defects have been noted or in case of doubts as to its proper function. Before further use an inspection by a competent person is needed or the defective parts have to be replaced.

- F 1. Fall arrest systems shall as need arises, however at least once per year be inspected and approved by competent person.

Exceptions:

Rigid type fall arrest systems with a guided fall arrester should be inspected as need arises by a competent person.

Competent person is a:

person who thanks to his education and experience in the field of personal protective equipment against falls from height has sufficient knowledge about applicable state and local safety regulations, applicable standards (e.g. EN-standards) and is thus capable and thus authorized by Söll of judging the correct status and use of systems and products against falls from height.

- F 2. Fall arresters must be examined by a competent person at least once a year and after every fall incident. In such cases refer to the relevant instructions of the fall arrester.
- F 3. Check the proper condition and functioning of all elements of the fall protection system before and during use.
- F 4. The end stops (Fig. 4/detail 4.0; Fig. 9a/b/detail 7.0/8.0) at the lower and upper end of the climbing path must have been installed. The pivotable lever (Fig. 4/detail 4.1; Fig. 9a/detail 7.1) at the right hand side of the rail must independently snap back into its initial position and thus block the fall arrester.

- F 5. Guide-rails must always be free of dirt.
- F 6. All bolt connections must be tightly fastened and secured, see section E.
- F 7. At every location of a fall arrest system where a fall arrester may be connected or disconnected to the system a permanent sign board with the following information shall be displayed:
 - Year of manufacture
 - System manufacturer's or importer's name
 - Type of fall system e.g. DIN EN 353-1
 - "Anyone using the system shall use a full body safety harness and an appropriate fall arrester"

Note: Sign Boards may consist of stamped aluminium plates.

G Check list for the inspection and approval of Söll-GlideLoc fall arrest systems

Y-Spar - Ladders Part No. YAL

Twin - Ladders Part No. ZAL

The check list on pages 28 - 30 must be fully and correctly compiled by the chief engineer of the installing company by means of an indelible pen. He is responsible for the correctness of all the information provided therein. Any checkpoint with a "No" remark must be explained under the defects, irregularities on page 30.

Control Activity

Remarks

(please cross)

yes no

- Every ladder section uses at least one mounting bracket. (see section B 16) yes no
- The fixing distance for Y-Spar ladder (YAL) is of 1680 mm maximum and of 2240 mm maximum for the Twin ladder (ZAL) and corresponds herewith to section B16. yes no
- The gaps at the guide-rail joints comply with section B 23. yes no
- The bolt connections between structure and mounting elements comply with sections B 8, B 9 and B 10. yes no
- The mounting elements are correctly installed and all bolt connections are tightly fastened. (tightening torques as per section B 17/B 24 are used) yes no
- Even screwed connections pre-assembled in the factory were inspected (for tightening torques see Section B 17/B 24) yes no
- All bolt connections are secured against loosening in accordance with section E. yes no
- A "Bottom End Stop" has been installed at the beginning of the climbing path in accordance with sections B 19/20. yes no
- A "Top End Stop" or a "Rigid End Stop" has been installed at the upper end of the climbing path in accordance with section B 29. yes no
- If the ascent route does not start directly at ground level, 2 ascending locks must be fitted as described in Section B 21. yes no
- Resting platforms have been properly installed at a distance of 10 m and were tested for functionality. (refer to section B 30 and B 31) yes no
- In accordance with section B 28 there are no rail projections of more than 525mm without extra reinforcement. yes no
- The rail reinforcement was installed in accordance with section B 28. yes no
- The maximum curve angels for curved sections are not exceeded (refer to section C) yes no
- The guide-rails are free of dirt. yes no
- Only anticorrosive, or hot dip galvanized mounting elements and bolt connections have been used. yes no
- The SÖLL fall arrester can only be inserted into the guide-rail in the direction in which it travels. yes no

Safety in Action

- System owner has at least two Söll fall arresters.
- Sign board is displayed.
- Test climbing has taken place.
- This manual was handed over to the operator.
- Only original components from Sperian Fall Protection Deutschland GmbH & Co. KG were used.

<input type="checkbox"/>	<input type="checkbox"/>
<input type="checkbox"/>	<input type="checkbox"/>
<input type="checkbox"/>	<input type="checkbox"/>
<input type="checkbox"/>	<input type="checkbox"/>
<input type="checkbox"/>	<input type="checkbox"/>

