

# Manual for the Installation Use and Maintenance "Söll-GlideLoc" fall arrest system Exit Section

**Hot Dip Galvanized Steel** Part.No. 11317

**Pickled Stainless Steel** Part.No. 16978

In accordance with EN 353, Part 1  
Serial Number

in conjunction with

**Söll Steel/Stainless Steel Ladders,**

as well as with

**Söll Guide Rails on existing ladder/step-iron walkways**

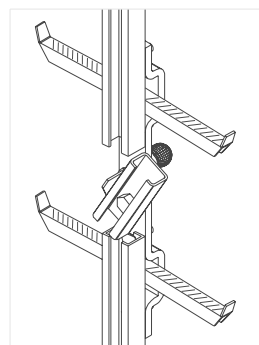
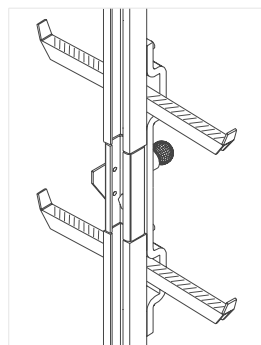

Date: 26.08.2008  
SE 8. b



# Table of contents

A	General	3
B	Preparing for the installation of the exit device	4
C	Installation of the exit section	6
D	Inspection and acceptance	9
E	Bolt connections/securing of bolts	9
F	Directions for use of the exit section	10
G	Maintenance of the exit section	11
H	Maintenance	11
I	Check list	13

**These instructions are protected by copyright!**

They may not be reproduced and distributed in any ways/  
by any means without prior written consent of the author  
according to Articles 16 and 17 of the German Copyright Act.  
Sperian Fall Protection Deutschland GmbH & Co. KG  
will prosecute any violations against this  
under Article 106 of the German Copyright Act.

**In this issue the following has been changed:**  
address

## A General

- A 1. Anyone working with or on SÖLL exit section in accordance with EN 353/part 1 must be familiarized with these instructions prior to using the system. Use which is not in accordance with these instructions constitutes a risk to human life!
- A 2. The operator of the fall protection system must ensure that these instructions are stored in a safe, dry place on site and that the user may have access to them any time.
- A 3. If requested, the plant operator must present these instructions to the manufacturer of the fall protection system (Sperian Fall Protection Deutschland GmbH & Co. KG or a dealer authorized by the same).
- A 4. The SÖLL fall protection system must be used in accordance with the instructions for the relevant SÖLL fall arrester.
- A 5. The fitment and use of SÖLL accessories to such fall protection systems must strictly adhere to the relevant instructions for the fitment and use thereof.
- A 6. In case of the use of further personal protective equipment, relevant instructions must be followed.
- A 7. National regulations on accident prevention and use of safety equipment for construction work must be adhered to.
- A 8. Söll fall protection systems may only be fitted and used with original Söll components/elements. The combination with non-original components/elements may influence the safety of SÖLL fall protection systems. In such cases, Sperian Fall Protection Deutschland GmbH & Co. KG and a dealer authorized by the same refuse to accept product liability. Full liability will therefore rest with the operator.
- A 9. Söll fall protection components, made of stainless steel grade 1.4571 are pickled. They should be stored and further processed in an appropriate way.
- A 10. The check list (see Section I) must be fully and correctly compiled by the chief engineer of the installing company by means of an indelible pen.
- A 11. Before and during the use of the installed exit section, the system must be visibly inspected to ensure that it is in safe operating condition.
- A 12. The system has been tested and approved by "Stelle 0158/DMT-Gesellschaft für Forschung und Prüfung mbH, Zertifizierungsstelle, Franz-Fischer-Weg 61, 45307 Essen".

## B Preparing for the installation of the exit device

### B 1. The assembly kit consists of:

- 1 swivel part with integrated base plate and bolts
- 1 cutting and drilling template

### B 2. Equipment required for easy fitting:

- 1-hack-saw
- 1-flat file, for removing burrs
- 1-ring endspanner, size 19 mm
- 2-open spanners, size 19 mm

At least one separate, additional safety rope in accordance with EN 355 with fitted energy absorber to provide additional protection against falls from a height during the assembly of the equipment.

### B 3. Personnel required for assembly:

At least two persons (the second person is for the purpose of providing help and possible rescue to the fitter).

B 4. Components must be handled carefully and never thrown.

B 5. Before installation, ladder sections must be cleaned from dirt - in particular on connecting surfaces. They should not come into contact with cement, mortar or similar substances. Remnants of mortar must be wiped off immediately. Especially the sliding surfaces for the fall arrester on the inside and outside of the guide-rail must be free of dirt.

B 6. Damaged parts may neither be used nor repaired but must be replaced by new ones.

### B 7. Caution:

The ladder sections may be installed directly from the ladder and without any scaffolding. The person installing the equipment uses a full-body harness and a fall arrester. In order to be protected against a fall from a height where the fall arrester slips from the rail, or the not completely installed ladder bends backwards, the installer must always use a safety lanyard with shock absorber in accordance to EN 354/355 (see Fig. 1).

**Fig. 1**

B 8. **For Söll ladders:** The safety rope must only be fastened to the last fixing bracket which is firmly attached to the building and the ladder.

**For Söll guide rails on existing step-irons and ladders which do not originate from Söll:**

Only positively fasten the safety rope to the rung or stirrup/step-iron which is on a level with the rear fastening ring of the full body harness. Check for sufficient stability of the anchorage.

Fig. 1

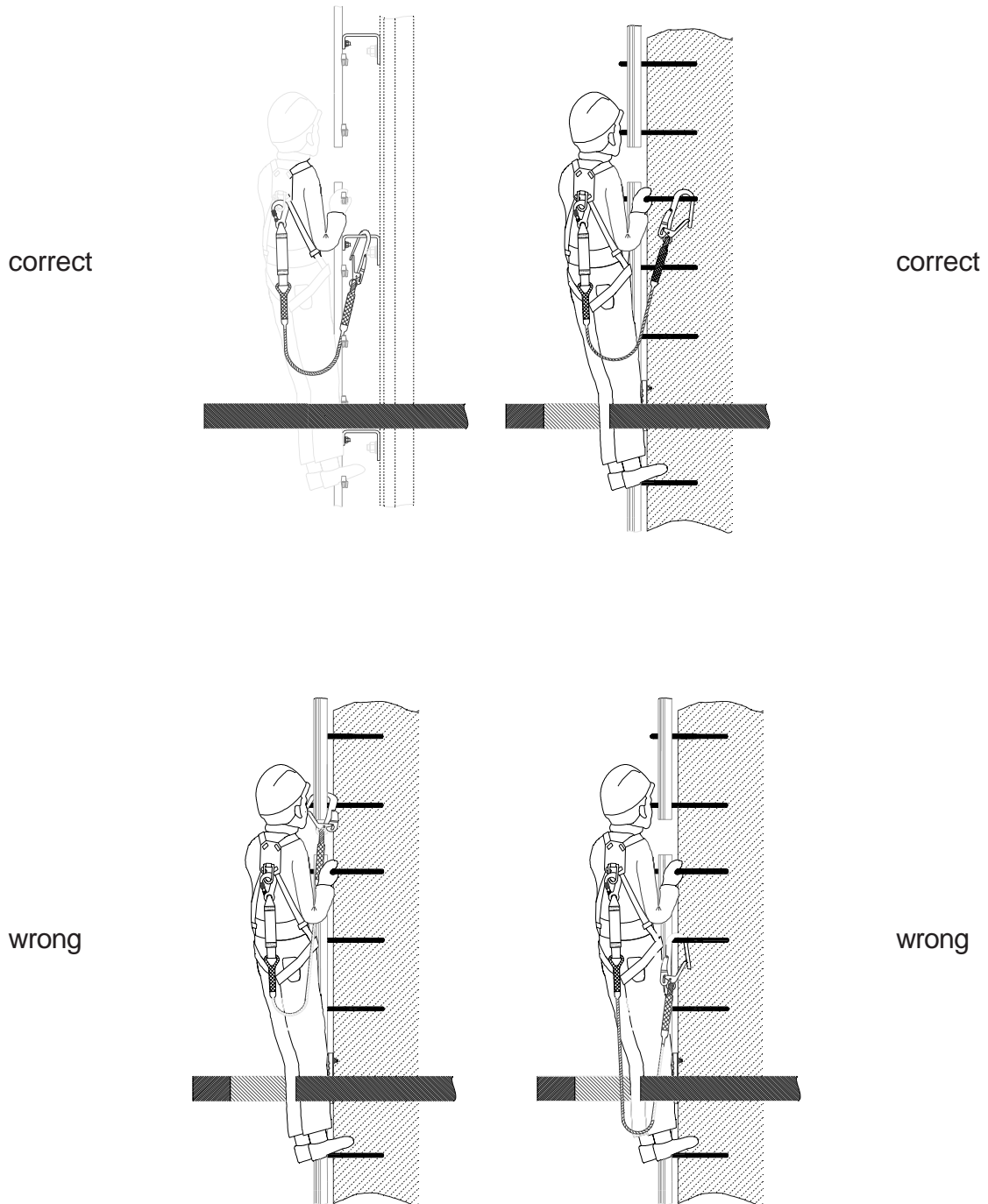

## C Installation of the exit section

C 1. The exit section is principally installed between two rungs of the ladder.

**Fig. 2**

C 2. The recommended height for installations is approximately 1.000 mm above the upper edge of the platform.

Fig. 2

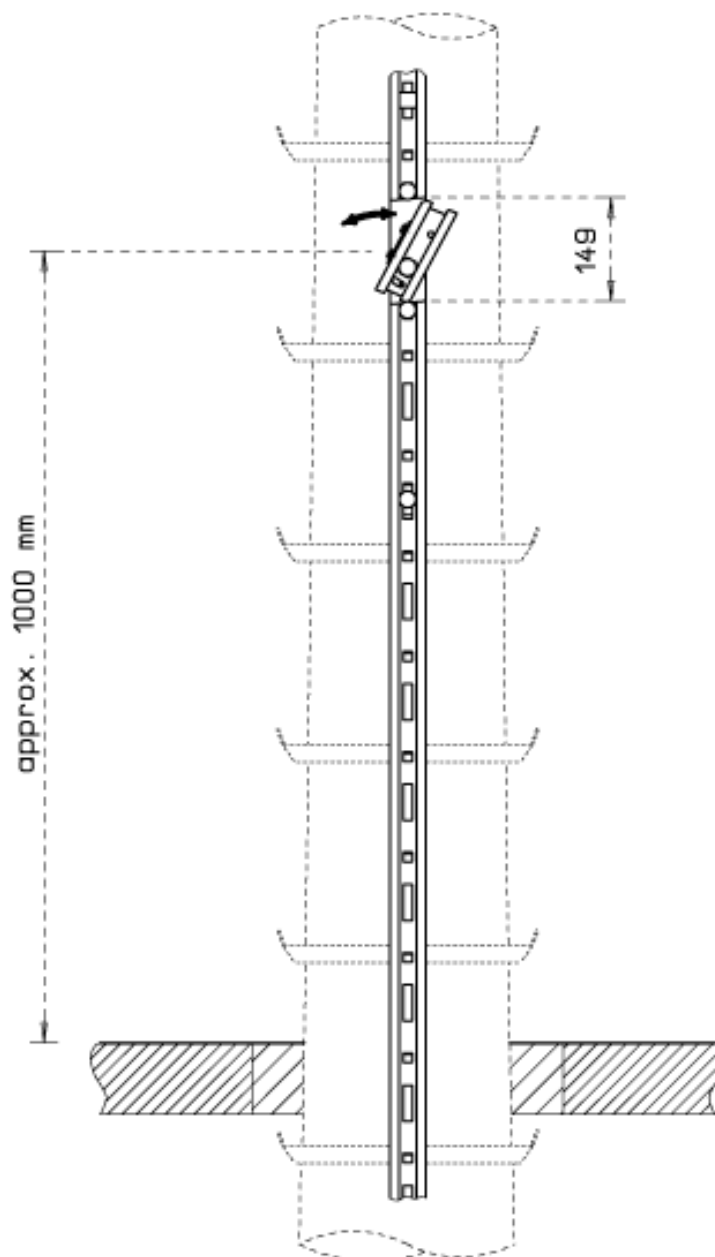

**Fig. 3a/b**

- Bolt the cutting template to the guide rail.

**Fig. 3a**

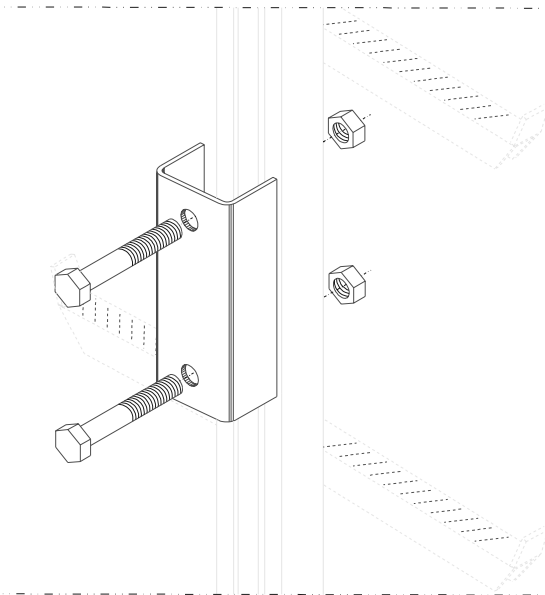

**Fig. 3b**

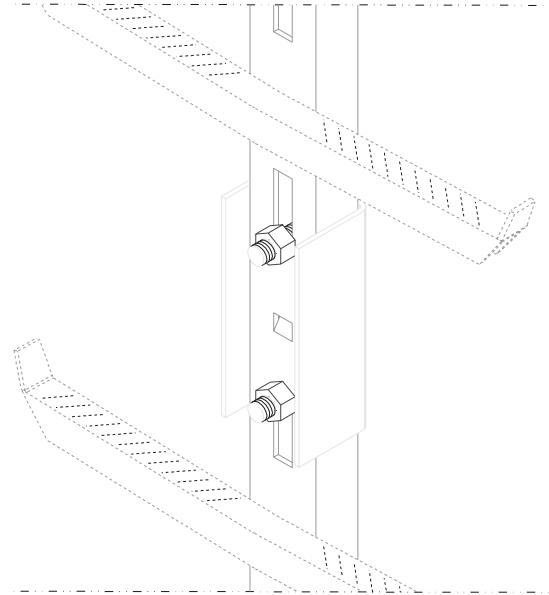

**Fig. 4**

- Cut out the segment of guide rail.

**Fig. 4**

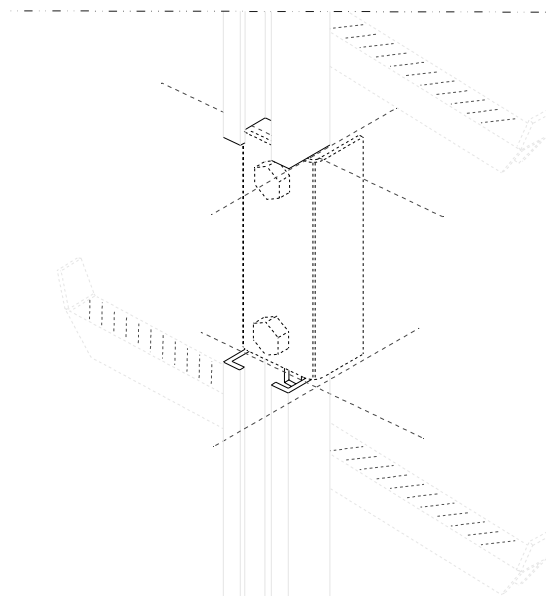

**Fig. 5**

When fitting the exit section, always make sure that the blocking device (1.1) is on the left hand side when viewed from the front of the ladder.

**Fig. 5**

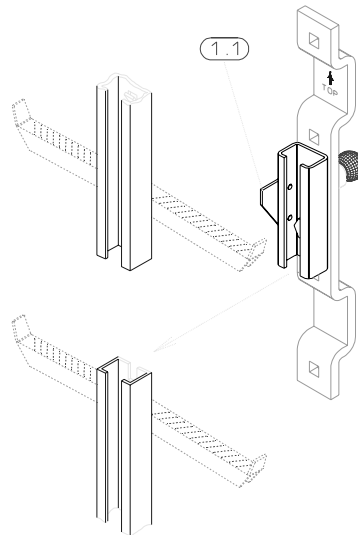

**Fig. 6**

- From the rear, fit the exit section to the guide rail with the wording „TOP“ pointing upwards and bolt in accordance with the diagram. Care must be taken that the bolt fixings are securely fastened and secured against loosening (see here Section E).

**Fig. 6**

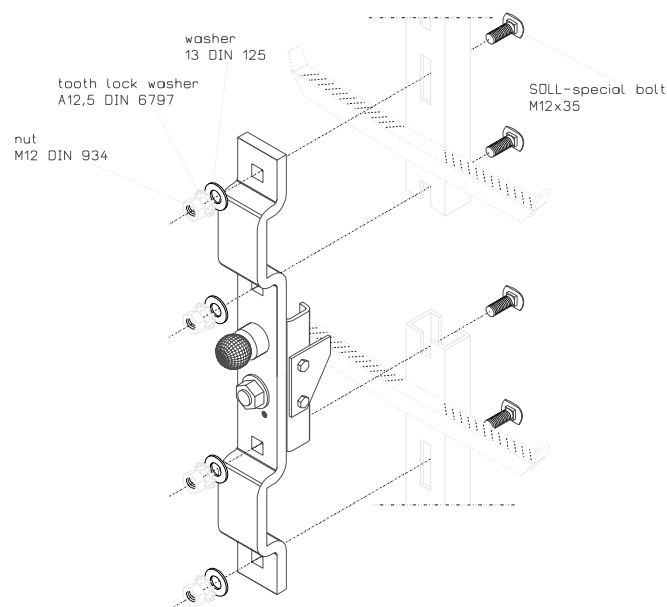

## **D Inspection and acceptance**

All bolt connections are to be inspected. They must be securely fastened and secured against loosening (see section E). The stop bolt (Fig. 7 item 2.0) on the rear side of the exit section must snap back into the locking bore hole independently. The swivel part of the exit section must be easy to turn between the two ends of the guide rail.

## **E Bolt connections/securing of bolts**

At use of hot dip galvanised screws the troth washer ensures satisfactory securing of the screw/nut connection.

At use of stainless steek screws self-locking nuts (nyloe or similar) shall be used.

## F Directions for use of the exit section

Fig. 7

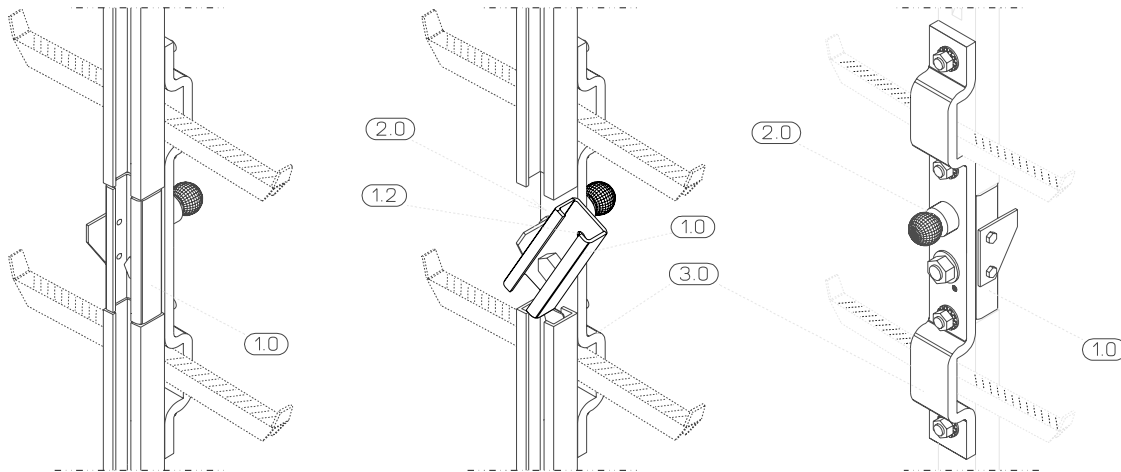

### F 1. Removing the guided-type fall arrester:

Move the fall arrester into the swivel part (1.0) of the exit section. Pull the stop bolt (2.0) on the rear of the base plate (3.0) backwards and turn the swivel part (1.0). Remove the fall arrester in an upward direction.

#### **Warning!**

Prior to the removal of the guided type fall arrester from the guide rail, ensure that another form of protection against a fall from a height is used.

F 2. The swivel part (1.0) should not stay open. Though after removing the fall arrester and not closing it, persons climbing afterwards cannot exit from the guide rail if the swivel part is open.

### F 3. Inserting the guided-type fall arrester:

Insert the fall arrester into the swivel part (1.0) with the safety pin pointing to the right. Turn the swivel part back into alignment with the climbing path. The stop bolt (2.0) on the rear side of the exit section snaps back into the locking bore hole (1.2) continue climbing.

## G Maintenance of the exit section

### **Warning!**

For reasons of safety, no repairs to any parts are to be carried out, unless by qualified personnel. Exit devices which have been damaged mechanically, e.g. after a fall from a height, must be exchanged.

- G 1. The exit section must, when required, at least once a year, be examined by a competent person to ensure it is in good working order.

### **Competent person is a:**

person who thanks to his education and experience in the field of personal protective equipment against falls from height has sufficient knowledge about applicable state and local safety regulations, applicable standards (e.g. EN-standards) and is thus capable of judging the correct status and use of systems and products against falls from height.

- G 2. Prior to/during every ascent ensure the function and conformity to regulations of all exit section elements.
- G 3. The stop bolt (Fig. 7/2.0) on the rear side of the exit section has to independently snap back into the locking bore hole in the swivel part (Fig. 7/1.0), thus preventing the opening of the exit section.
- G 4. Ensure that the guide rail is free from any dirt.
- G 5. All bolt connections must be securely fastened and secured against loosening, see section E.
- G 6. Prior to and during each usage, the exit section is to be checked with regard to function in accordance with the check list in Section (I).

## H Maintenance

- H 1. If required, the exit section can be cleaned using warm water and a hand-brush. After washing, dry with a clean cloth. Do not use fat or oil dissolving quick cleaning dilution or cold cleaners.
- H 2. If needed, oil the stop bolt (Fig. 7/2.0) and the swivel part (Fig. 7/1.0).



# I Check list for the inspection and approval of Söll-GlideLoc fall arrest systems

Part.No. 11317 and 16978

The check list on pages 13/14 must be fully and correctly completed by the chief engineer of the assembling company using an indelible pen. He is responsible for the correct nature of all information provided. Check points which reveal defects or variations are to be entered in the list „Space for Comments“ on page 14.

## Control activity

## Inspection remarks

(please cross)  
if OK

- The bolt connections are all securely fastened.
- All bolt connections are secured against loosening in accordance with section E.
- The exit section is free from all dirt.
- Only corrosion-proof bolt connections have been used.
- The Söll guided type fall arrester can only be inserted into the climbing path in the effective direction in which it travels. (Blocking device (Fig. 5/Detail 1.1) is on the left-hand side).
- The stop bolt (Fig. 7/Detail 2.0) on the rear side of the exit section slips back into the locking bore (Fig. 7/Detail 1.2) hole independently.
- The stop bolt is free from dirt.
- The swivel part (Fig. 7/Detail 1.0) can be easily swivelled after pulling out the stop bolt.
- The upper edge of the swivel part does not touch the upper guide rail when swivelling closed.
- The lower edge of the swivel part does not touch the lower guide rail when swivelling closed.
- The base (Fig. 7/Detail 3.0) plate is securely fitted.
- The guided type fall arrester does not slide out of the ladder guide rails joining to the top or the bottom whilst the swivel part is open.
- The guided type fall arrester can only be removed from the swivel part in an upward direction.
- Test walk/climb carried out.
- No defects or shortcomings were found.
- These instructions were handed over to the operator.
- Only original Sperian Fall Protection Deutschland GmbH & Co. KG, Fall Protection Engineering components were used.

no  yes

